



FEDERAL SIGNAL VAMA

Protecting people and our planet

SOUNDSTAR D Series

Compact sirens and speakers



SOUNDSTAR D Series

Federal Signal Vama introduces New **Soundstar D Series**, with significant added values in relation to its IP protection and operability. This powerful acoustic signalling system with built-in amplifier and loudspeaker in a single unit also offers:



SETTING TONES: 32 selectable tones selected from outside by the end user or installer, through main wiring harness.

R10

APPROVED: Comply with R10 European Regulation.



IMPACT RESITANT HOUSING: ABS structure with glass fiber and injected aluminium.



SEALED WIRING: The output sealed wiring design provides IPX9K Protection Approval, against high pressure and temperature.

Available colours:

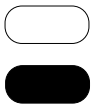

Approvals

- SoundStar Series comply with the R10 European Regulation.
- SoundStar Series comply with IPX9K Protection Approval.
- SCS1000-DN siren with ALS1000-DN speaker comply with the Italian siren standard.
- SCS1000-DN siren comply with the French siren standard.



Siren tone visor

TECHNOLOGIES:

- Ferrite Driver.
- Neodymium Driver.



Silent block kit (lower view)



MAIN FEATURES:

- 30W Compact siren, integrating siren amplifier and speaker in one compact unit, simplifying vehicle installation.
- Combinable with ALS1000-D speaker (30W + 30W).
- 32 programmed tones selected from outside through main wiring harness by the end user or installer.*
* Specify optional tone selected when ordering.



APPLICATIONS:

- Its compact design is suitable for police motorcycles installation.
- White version recommended for outside roof installations on emergency and service vehicles.

ACCESSORIES:

- Public Address.
- Silent Block kit.
- Complete wiring harness for motorcycle equipments.

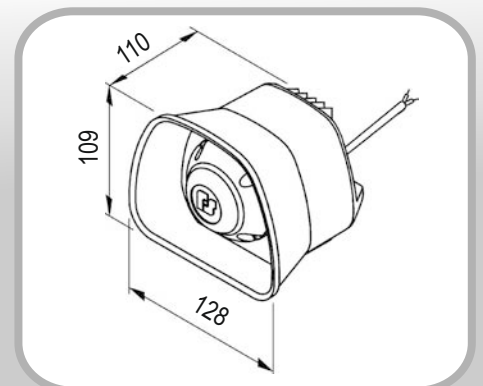

ALS1000-D Speaker dimensions in mm.

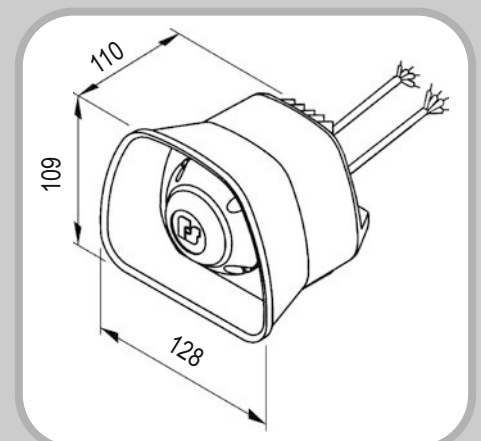

SCS1000-D Siren dimensions in mm.

TECHNICAL SPECIFICATIONS		
	FERRITE	NEODYMIUM
Voltage	12V	
Operating temperature	-30°C to +50°C	
Output power	30W + 30W	
Coil impedance	6 Ohms	
Maximum consumption	3Amp (SCS1000-D) 6Amp (SCS1000-D + ALS1000-D)	
Output voltage	23Vpp	
Frecuencias and tones	32 selectable tones	
Acoustic pressure to 2m at 12v. Two tones (450Hz and 600Hz to 33c/m) (SCS1000-D)	109 dBA	111 dBA
Acoustic pressuer to 3,5m at 12v. Two tones (450Hz and 600Hz at 33c/m) (SCS1000-D + ALS1000-D)	114 dBA	116 dBA
Dimensions	135 x 110 x113 mm	
Siren Weight	1.250 g	1.085 g
Speaker Weight	1.135 g	0,970 g

HOW TO ORDER

Select the part number from the following list:

SCS1000-D COMPACT SIREN	
Ferrite Driver	
2020277	SCS1000-D, 30W Compact Siren, ferrite driver, 32 selectable tones, w/ mounting hardware, w/o wiring harness, 12V, black colour
2020277-BL	SCS1000-DBL, 30W Compact Siren, ferrite driver, 32 selectable tones, w/ mounting hardware, w/o wiring harness, 12V, white colour
Neodymium Driver	
2020277N	SCS1000-DN, 30W Compact Siren, neodymium driver, 32 selectable tones, w/ mounting hardware, w/o wiring harness, 12V, black colour
ALS1000-D COMPACT SPEAKER	
Ferrite Driver	
2020278	ALS1000-D, 30W Compact speaker, 6 Ohms, ferrite driver, reduced dimensions, 12V, black colour
2020278-BL	ALS1000-DBL, 30W Compact speaker, 6 Ohms, ferrite driver, reduced dimensions, 12V, white colour
Neodymium Driver	
2020278N	ALS1000-DN, 30W Compact speaker, 6 Ohms, neodymium driver, reduced dimensions, 12V, black colour
Accesories	
8216113	SCS1000-PA, Public address kit, w/ volume and microphone functions control
8299306	SCS1000-BLOCK, Silent block kit, SCS1000-D / ALS1000-D
8299910	Sealed connector for SCS1000-D
82441589	Motorcycle complete wiring harness (LD410, CO400, SCS1000-D and control head)
82441588	Motorcycle complete wiring harness (LD400, CO400, SCS1000-D and control head)
82441605	Adapter wiring from SCS1000 to SCS1000-D
Serie MC300	
4004233-01	MC300, Motorcycle Control allows to control all the functions of lights and siren of the 400 Solaris Series: priority warning lights (LD400 Solaris and CO400 Solaris, "Stop Light" function, cruise light and continuous siren
4004352	MC300/A, Motorcycle Control allows to control all the functions of lights and siren of the 400 Solaris Series: priority warning lights (LD400 Solaris and CO400 Solaris, "Stop Light" function, cruise light, continuous siren and power limiter